

### DESCRIPTION

The MP2420 is a step-down switching regulator with integrated high- and low-side, high-voltage power MOSFETs. It achieves a highly efficient output of up to 0.3A, and the integrated watchdog adds additional security redundancy to the system.

The wide 4.5V to 75V input range accommodates a variety of step-down applications in an automotive environment. A 5µA shutdown mode quiescent current in a full temperature range is ideal for battery-powered applications.

The MP2420 allows for high-power conversion efficiency over a wide load range by scaling down the switching frequency under light-load conditions to reduce switching and gate driver losses. The start-up switching frequency and short circuit can also be scaled down to prevent an inductor current runaway.

Full protection features include under-voltage lockout (UVLO) and thermal shutdown. Thermal shutdown provides reliable, fault-tolerant operation.

The MP2420 is available in a TSSOP-16 EP package.

### FEATURES

- 20µA Quiescent Current for Buck Only
- Wide 4.5V to 75V Operating Input Range (80V ABS MAX)
- 1.2Ω/0.45Ω Internal Power MOSFETs
- Programmable Soft Start
- FB Tolerance: 1% at Room Temperature, 2% at Full Temperature
- Adjustable Output Voltage
- Integrated Window Watchdog
- Power-On Reset during Power Up and Under-Voltage Lockout (UVLO)
- Programmable Short Window Mode or Long Window Mode
- Low Shutdown Mode Current of 5µA
- Available in a TSSOP-16 EP Package

### APPLICATIONS

- Automotive Systems
- Industrial Power Systems
- Distributed Power Systems
- Battery-Powered Systems

All MPS parts are lead-free, halogen-free, and adhere to the RoHS directive. For MPS green status, please visit the MPS website under Quality Assurance. "MPS" and "The Future of Analog IC Technology" are registered trademarks of Monolithic Power Systems, Inc.

### TYPICAL APPLICATION

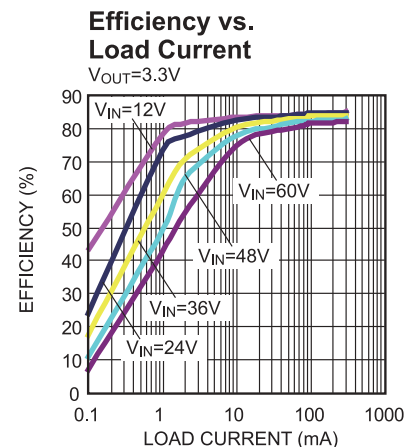
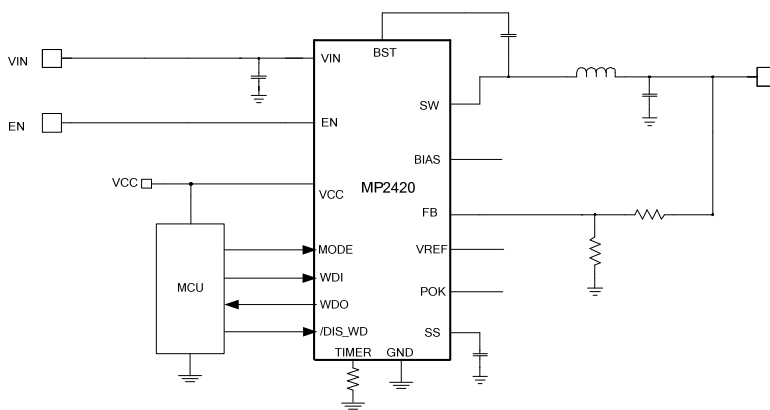

## ORDERING INFORMATION

Part Number*	Package	Top Marking
MP2420GF	TSSOP-16 EP	<i>See Below</i>

\* For Tape & Reel, add suffix -Z (e.g. MP2420GF-Z)

## TOP MARKING

**MPSYYWW**

**MP2420**

**LLLLLL**

MPS: MPS prefix  
 YY: Year code  
 WW: Week code  
 MP2420: Part code of MP2420GF  
 LLLLLL: Lot number

## PACKAGE REFERENCE

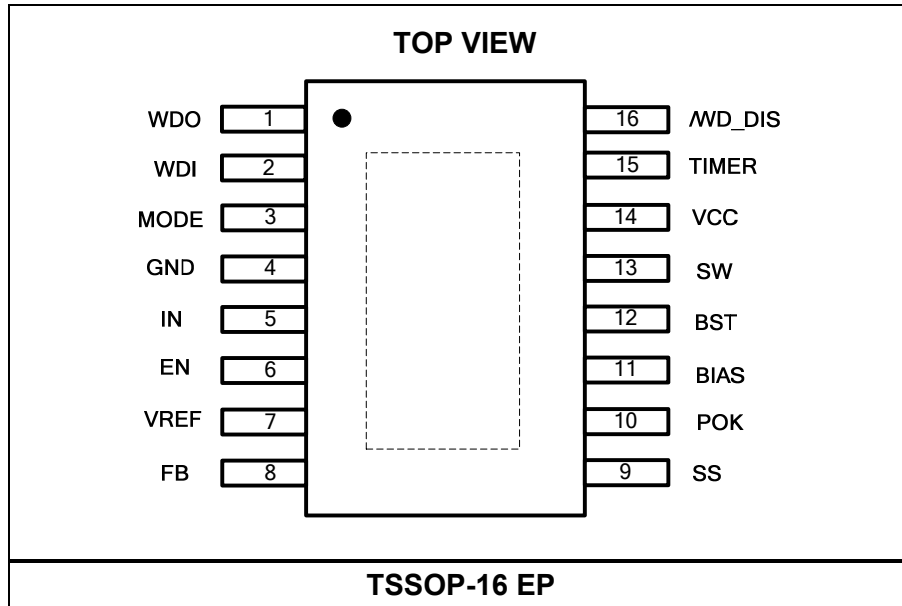

**ABSOLUTE MAXIMUM RATINGS** <sup>(1)</sup>

Supply voltage ( $V_{IN}$ ) .....	-0.3V to +80V
Switch voltage ( $V_{SW}$ ) .....	-0.3V to $V_{IN} + 1V$
BST to SW .....	-0.3 to +6.0V
All other pins .....	-0.3V to +6.0V
EN sink current .....	150 $\mu$ A
Continuous power dissipation ( $T_A = +25^\circ\text{C}$ ) <sup>(2)</sup>	
TSSOP-16 EP .....	2.7W
Junction temperature .....	150 $^\circ\text{C}$
Lead temperature .....	260 $^\circ\text{C}$
Storage temperature .....	-65 $^\circ\text{C}$ to +150 $^\circ\text{C}$

**Recommended Operating Conditions** <sup>(3)</sup>

Supply voltage ( $V_{IN}$ ) .....	4.5V to 75V
Output voltage ( $V_{OUT}$ ) .....	1V to $0.9 \times V_{IN}$
Operating junction temp. ( $T_J$ ) .....	-40 $^\circ\text{C}$ to 125 $^\circ\text{C}$

<b>Thermal Resistance</b> <sup>(4)</sup>	$\theta_{JA}$	$\theta_{JC}$
TSSOP-16 EP .....	45.....	10... $^\circ\text{C/W}$

**NOTES:**

- 1) Exceeding these ratings may damage the device.
- 2) The maximum allowable power dissipation is a function of the maximum junction temperature  $T_J$  (MAX), the junction-to-ambient thermal resistance  $\theta_{JA}$ , and the ambient temperature  $T_A$ . The maximum allowable continuous power dissipation at any ambient temperature is calculated by  $P_D$  (MAX) =  $(T_J$  (MAX) -  $T_A$ ) /  $\theta_{JA}$ . Exceeding the maximum allowable power dissipation produces an excessive die temperature, causing the regulator to go into thermal shutdown. Internal thermal shutdown circuitry protects the device from permanent damage.
- 3) The device is not guaranteed to function outside of its operating conditions.
- 4) Measured on JESD51-7, 4-layer PCB.

## ELECTRICAL CHARACTERISTICS

$V_{IN} = 24V$ ,  $V_{EN} = 2V$ ,  $V_{CC} = 5V$ ,  $T_J = +25^{\circ}C$ , unless otherwise noted.

Parameter	Condition	Min	Typ	Max	Units
<b>DC/DC Converter</b>					
Supply quiescent current	No load, $V_{FB} = 1.2V$		20	25	$\mu A$
Shutdown supply current	$V_{EN} < 0.3V$		2.2	3.5	$\mu A$
$V_{IN}$ UVLO rising threshold		3.9	4.2	4.4	V
$V_{IN}$ UVLO falling threshold		3.45	3.75	3.95	
$V_{IN}$ UVLO hysteresis			0.45		V
Feedback voltage	$V_{IN} = 4.5V$ to $75V$ , $T_J = 25^{\circ}C$	0.99	1.0	1.01	V
	$V_{IN} = 4.5V$ to $75V$ , $-40^{\circ}C < T_J < 125^{\circ}C$	0.98	1.0	1.02	V
Feedback current	$V_{FB} = 1.2V$	-50	2	50	nA
$V_{REF}$ voltage	$V_{IN} = 4.5V$ to $75V$ , $I_{REF} = 100\mu A$	0.965	1	1.035	V
Upper switch-on resistance	$V_{BST} - V_{SW} = 5V$	0.9	1.2	1.5	$\Omega$
Lower switch-on resistance	$V_{BIAS} = 5V$	0.275	0.45	0.625	$\Omega$
Lower switch leakage	$V_{EN} = 0V$ , $V_{SW} = 75V$			1	$\mu A$
Peak current limit		670	730	790	mA
Minimum switch-on time <sup>(5)</sup>			120		ns
Enable rising threshold		1.25	1.55	1.85	V
Enable falling threshold		1.152	1.2	1.248	V
Enable threshold hysteresis			0.35		V
Enable current	$V_{EN} = 2.4V$		0.8		$\mu A$
Soft-start current		4	5.5	7	$\mu A$
POK upper trip threshold	FB respect to the nominal value	86	90	94	%
POK lower trip threshold	FB respect to the nominal value	81	85	89	%
POK threshold hysteresis	FB respect to the nominal value		5		%
POK deglitch timer			40		$\mu s$
POK output voltage low	$I_{SINK} = 1mA$			0.4	V
FB OVP rising threshold			1.05	1.1	V
FB OVP hysteresis			50		mV
Thermal shutdown <sup>(5)</sup>			175		$^{\circ}C$
Thermal shutdown hysteresis <sup>(5)</sup>			20		$^{\circ}C$

**NOTE:**

5) Derived from bench characterization. Not tested in production.

**ELECTRICAL CHARACTERISTICS (continued)**
**V<sub>IN</sub> = 24V, V<sub>EN</sub> = 2V, V<sub>CC</sub> = 5V, T<sub>J</sub> = 25°C, unless otherwise noted.**

Parameter	Symbol	Condition	Min	Typ	Max	Units
<b>Watchdog Power Supply</b>						
Timer voltage		R <sub>TIMER</sub> = 51k		0.3		V
Quiescent current	I <sub>Q</sub>	R <sub>TIMER</sub> = 100k		16	19	μA
		R <sub>TIMER</sub> = 51k		25	32	μA
Power-on reset threshold	V <sub>POR-HIGH</sub>	WDO goes high with rising V <sub>CC</sub>	4.4	4.6	4.8	V
	V <sub>POR-LOW</sub>	WDO goes low with falling V <sub>CC</sub>	4.3	4.5	4.7	V
<b>Watchdog Timing</b>						
Single period	T	R <sub>TIMER</sub> = 51k	-10%	880	+10%	μs
Power-on delay <sup>(6)</sup>	t <sub>0</sub>	R <sub>TIMER</sub> = 51k		10		cycle
Sync signal monitoring time <sup>(6)</sup>	t <sub>1</sub>	R <sub>TIMER</sub> = 51k		450		cycle
Watchdog window close time (short mode) <sup>(6)</sup>	t <sub>2</sub>	R <sub>TIMER</sub> = 51k, mode = low		15		cycle
Watchdog window open time (short mode) <sup>(6)</sup>	t <sub>3</sub>	R <sub>TIMER</sub> = 51k, mode = low		10		cycle
Watchdog window close time (long mode) <sup>(6)</sup>	t <sub>4</sub>	R <sub>TIMER</sub> = 51k, mode = high		1500		cycle
Watchdog window open time (long mode) <sup>(6)</sup>	t <sub>5</sub>	R <sub>TIMER</sub> = 51k, mode = high		1000		cycle
WDO reset pulse width <sup>(6)</sup>	t <sub>6</sub>	R <sub>TIMER</sub> = 51k		4		cycle
WDI_OK pulse width			10		5000	μs
<b>Watchdog Input and Output</b>						
WDI logic high			3.2			V
WDI logic low					0.8	V
MODE logic high			3.2			V
MODE logic low					0.8	V
MODE input current		MODE = 5V		0.1	1	μA
		MODE = 0V		5	8	μA
/WD_DIS logic high			3.2			V
/WD_DIS logic low					0.8	V
/WD_DIS input current		WD_DIS = 5V		0.1	1	μA
		WD_DIS = 0V		5	8	μA
WDO high		V <sub>CC</sub> = 5V, I <sub>WDO</sub> = 1mA	V <sub>CC</sub> -0.2			V
WDO low		V <sub>CC</sub> = 5V, I <sub>WDO</sub> = 1mA			0.2	V
		V <sub>CC</sub> = 1V, I <sub>WDO</sub> = 300μA			0.1	V

**NOTE:**

6) Guaranteed by design.

# TYPICAL CHARACTERISTICS

## DC/DC CONVERTER

$V_{IN} = 12V$ , unless otherwise noted.

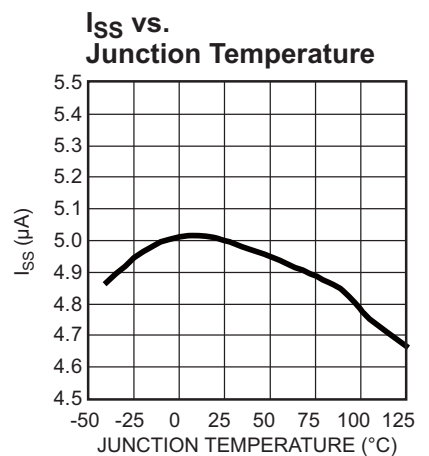
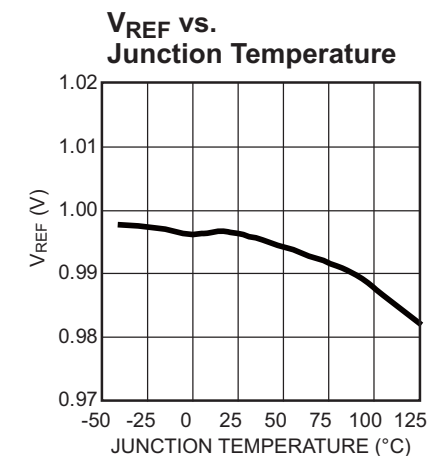
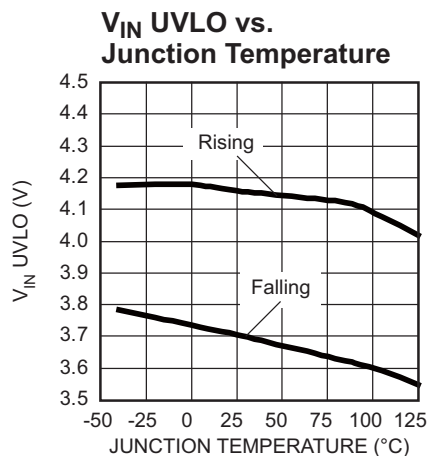
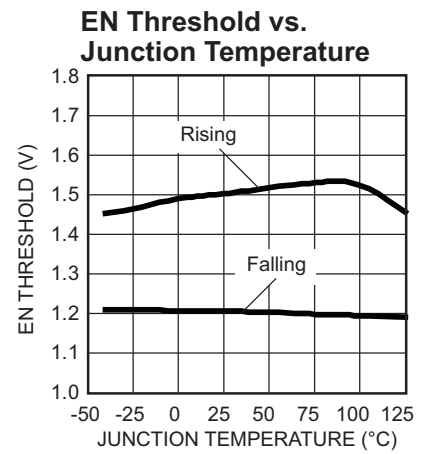
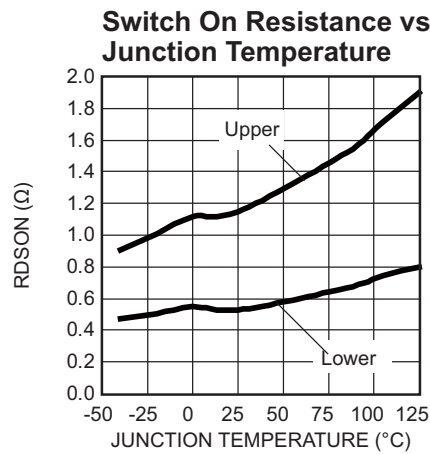
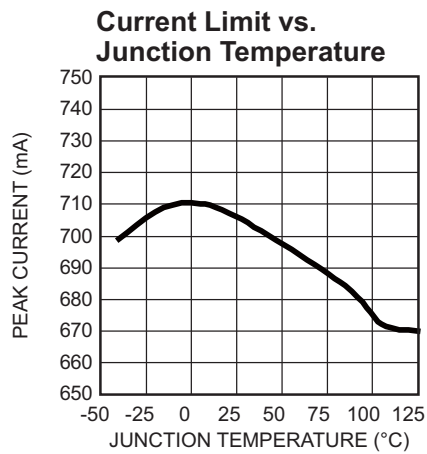
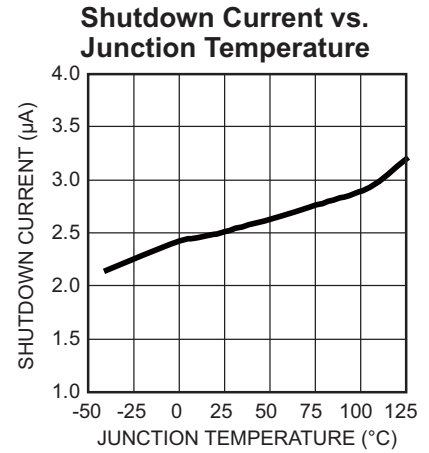
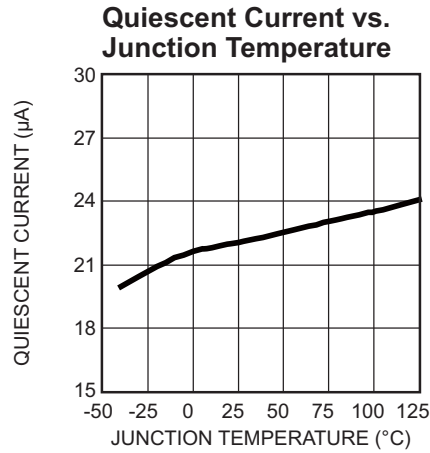
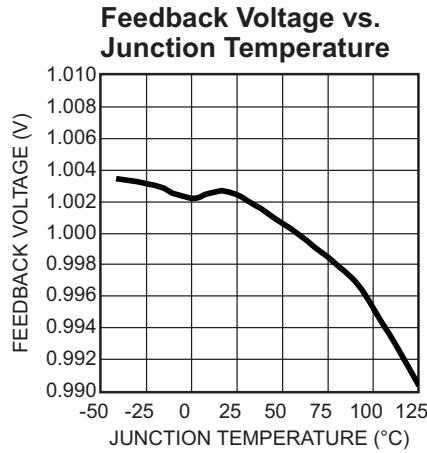

**TYPICAL CHARACTERISTICS (continued)**  
**WATCHDOG**

**Quiescent Current vs. Junction Temperature**

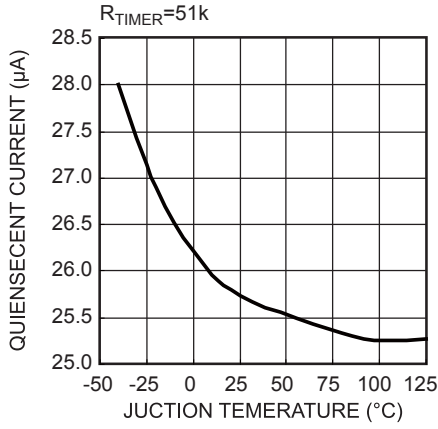

**Quiescent Current vs. Junction Temperature**

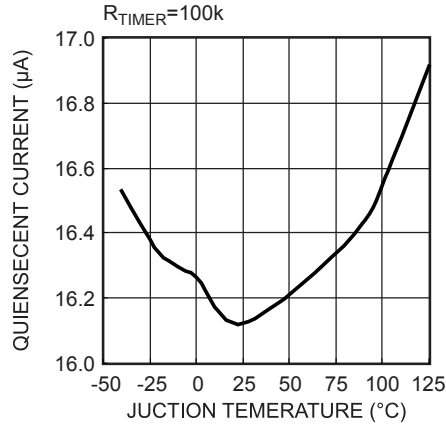

**Single Period vs. Junction Temperature**

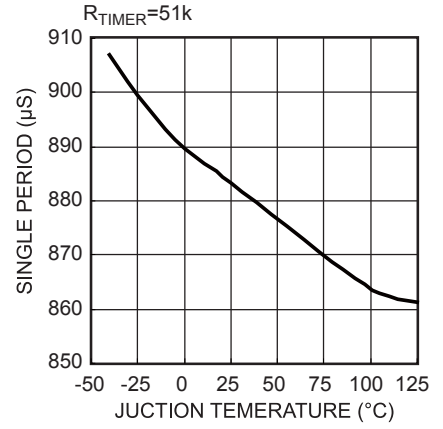

**Single Period vs. RTIMER**

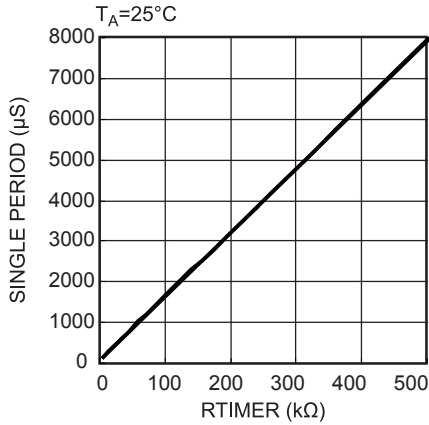

# TYPICAL PERFORMANCE CHARACTERISTICS

## DC-DC CONVERTER

$V_{IN} = 12V$ ,  $V_{OUT} = 3.3V$ ,  $L = 33\mu H$ ,  $C_{OUT} = 2 \times 22\mu F$ ,  $T_A = 25^\circ C$ , unless otherwise noted.

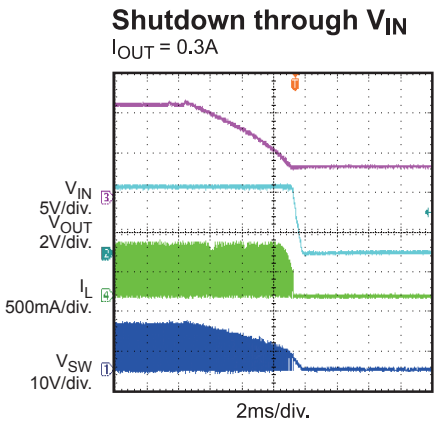
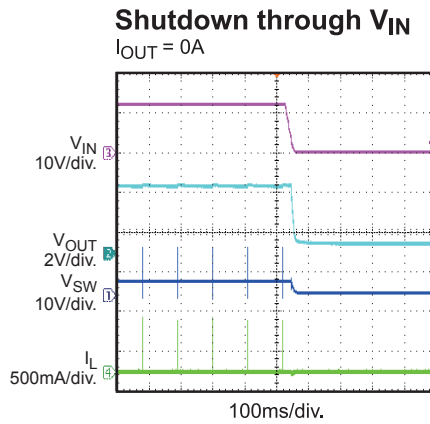
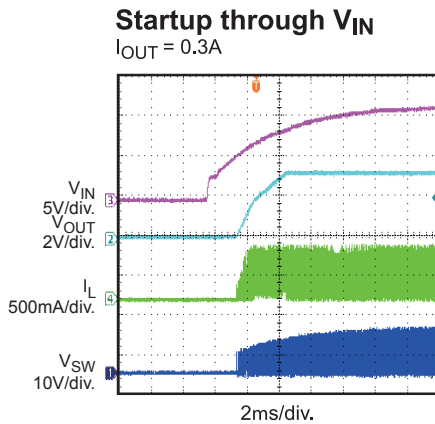
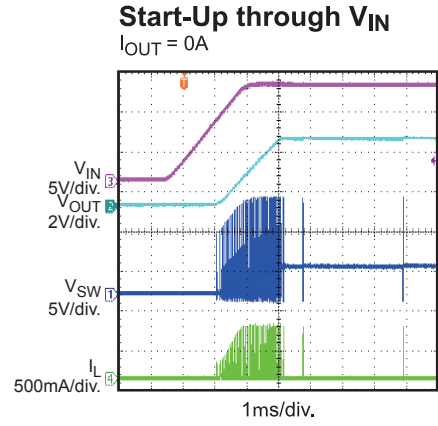
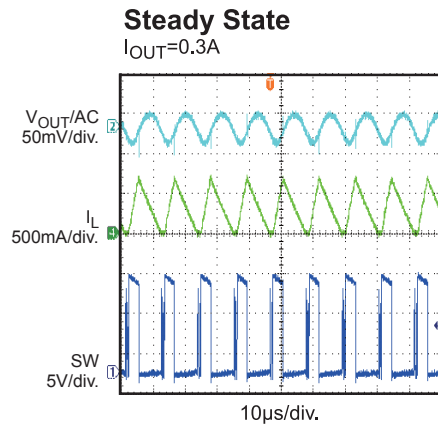
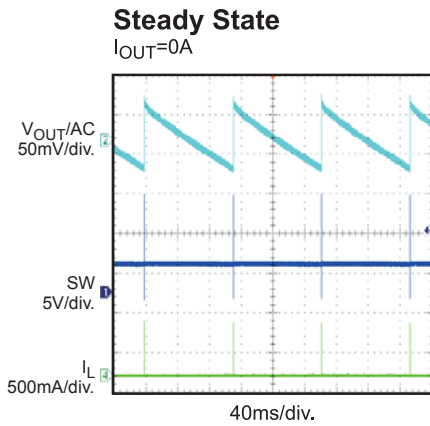
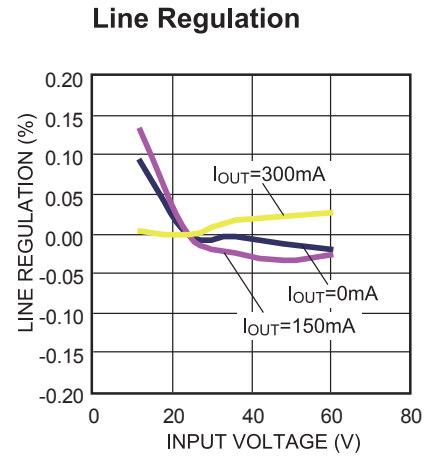
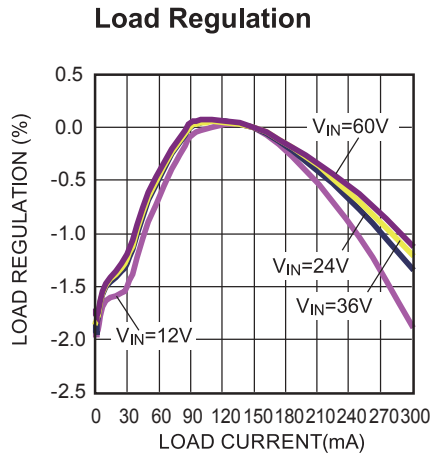
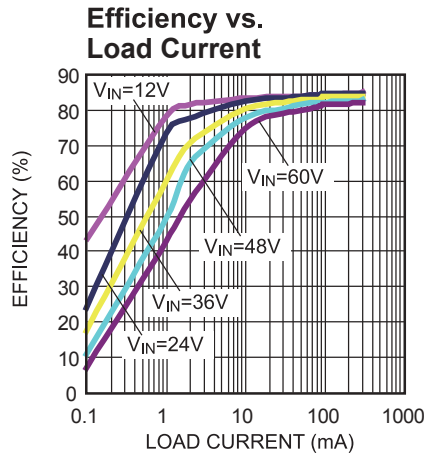



**TYPICAL PERFORMANCE CHARACTERISTICS (continued)**

$V_{IN} = 12V$ ,  $V_{OUT} = 3.3V$ ,  $L = 33\mu H$ ,  $C_{OUT} = 2 \times 22\mu F$ ,  $T_A = 25^\circ C$ , unless otherwise noted.

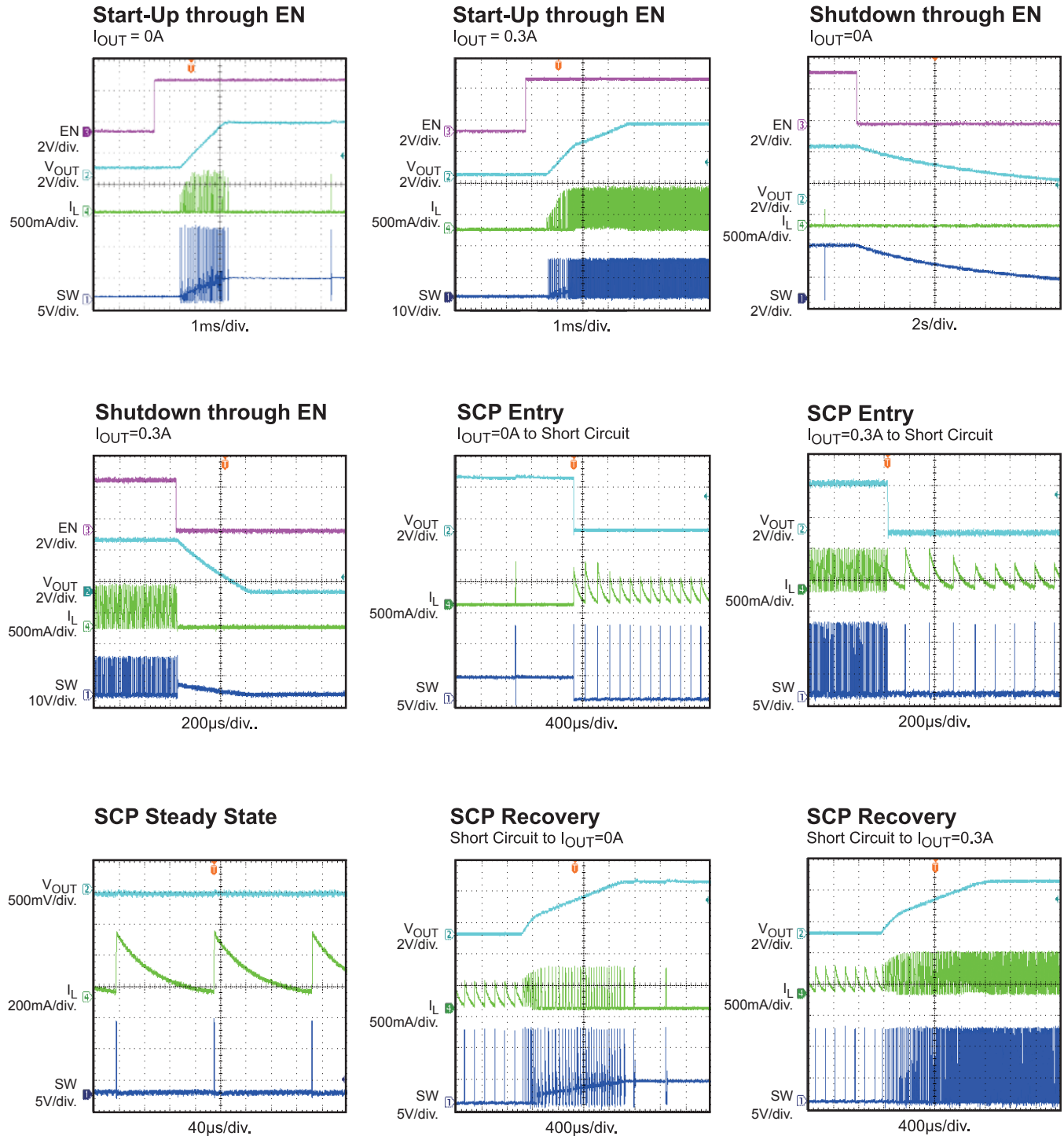

## PIN FUNCTIONS

Pin #	Name	Description
<b>Watchdog</b>		
1	WDO	<b>Watchdog output.</b> WDO outputs the reset signal to the MCU.
2	WDI	<b>Watchdog input.</b> WDI receives the trigger signal from the MCU.
3	MODE	<b>Mode switching.</b> Pull MODE high to make the watchdog work in long window mode; pull MODE low to make the watchdog work in short window mode. MODE has a weak internal pull-up.
4	GND	<b>Ground.</b> Connect GND as close the output capacitor as possible to avoid high-current switch paths.
14	VCC	<b>Power input.</b>
15	TIMER	<b>Watchdog timer.</b> Set the time-out with an external resistor.
16	/WD_DIS	<b>Watchdog disable.</b> Pull /WD_DIS low to disable the watchdog; pull /WD_DIS high to enable the watchdog. /WD_DIS has a weak internal pull-up.
<b>DC/DC</b>		
4	GND	<b>Ground.</b> Same as GND in Watchdog.
5	IN	<b>Input supply.</b> IN requires a decoupling capacitor connected to ground to reduce switching spikes.
6	EN	<b>Enable input.</b> Pull EN below the low threshold to shut the chip down; pull EN above the high threshold to enable the chip. Float EN to shut the chip down.
7	VREF	<b>Reference voltage output.</b>
8	FB	<b>Feedback input to the error amplifier (for QFN-10 (3mmx3mm) package only).</b> Connect FB to the tap of an external resistive divider between output and GND. FB sets the regulation voltage when compared to the internal 1V reference.
9	SS	<b>Soft-start control input.</b> Connect a capacitor from SS to GND to set the soft-start period.
10	POK	<b>Open-drain power good output.</b> A high output indicates that $V_{OUT}$ is higher than 90% of the reference. POK is pulled down during shutdown.
11	BIAS	<b>Controller bias input.</b> BIAS supplies a current to the internal circuit when $V_{BIAS} > 2.9V$ . BIAS is the feedback input for the SOIC-8 E package, which has a fixed output only.
12	BST	<b>Bootstrap.</b> BST is the positive power supply for the internal floating high-side MOSFET driver. Connect a bypass capacitor between BST and SW.
13	SW	<b>Switch node.</b>
	Exposed Pad	<b>Connect the exposed pad to the GND plane for optimal thermal performance.</b>

### FUNCTIONAL BLOCK DIAGRAM

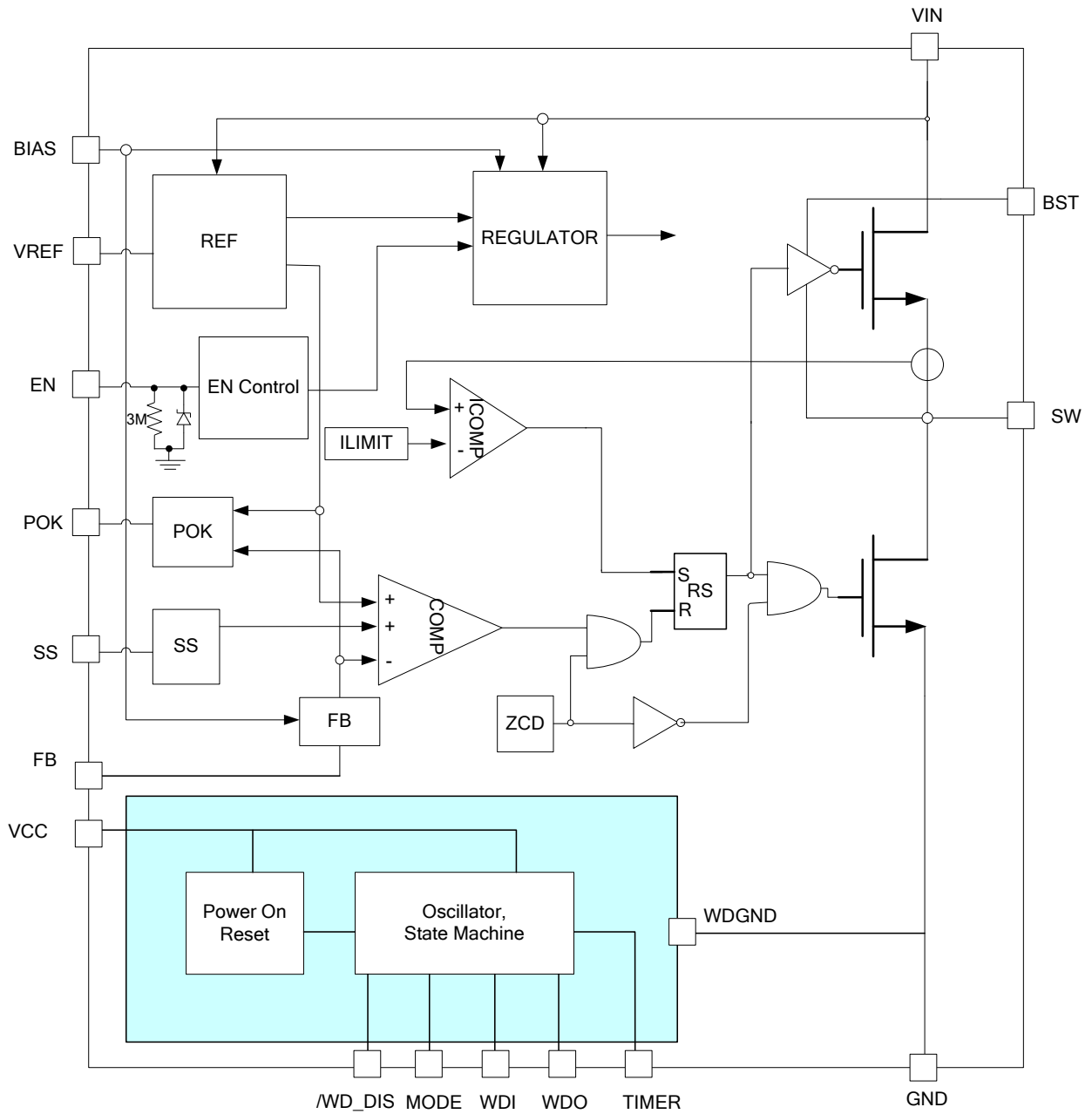

Figure 1: Functional Block Diagram

## OPERATION

### DC/DC SECTION:

The MP2420 is a 75V, 0.3A, synchronous step-down, switching regulator with integrated high-side and low-side, high-voltage power MOSFETs (HS-FET and LS-FET, respectively). It provides a highly efficient 0.3A output and features a wide input voltage range, external soft-start control, and precision current limit. It has a very low operational quiescent current, making it suitable for battery-powered applications.

### Control Scheme

The ILIM comparator, FB comparator, and zero current detector (ZCD) block control the PWM (see Figure 2). If  $V_{FB}$  is below the 1V reference and the inductor current drops to zero, the HS-FET turns on, and the ILIM comparator begins sensing the HS-FET current. When the HS-FET current reaches its limit, the HS-FET turns off, and the LS-FET and ZCD block turn on. The ILIM comparator turns off to reduce the quiescent current. The LS-FET and ZCD block turn off after the inductor current drops to zero. If  $V_{FB}$  is below the 1V reference at this time, the HS-FET turns on and begins another cycle. If  $V_{FB}$  is still higher than the 1V reference, the HS-FET remains off until  $V_{FB}$  drops below 1V.

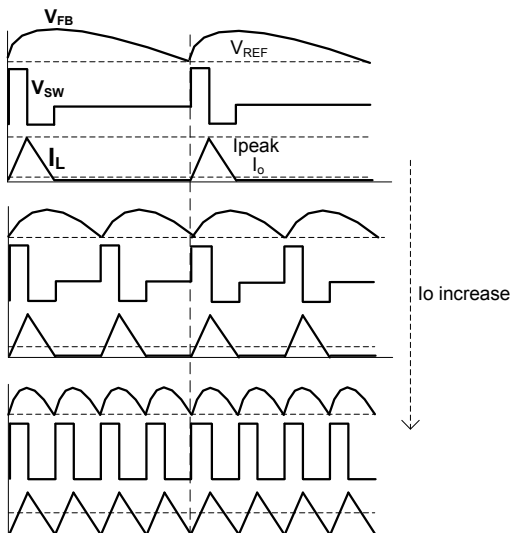

**Figure 2: Control Scheme**

### Internal Regulator and BIAS

The 2.6V internal regulator powers most of the internal circuitry. This regulator takes  $V_{IN}$  and operates in the full  $V_{IN}$  range. When  $V_{IN}$  is greater than 3.0V, the output of the regulator is in full regulation. Lower values of  $V_{IN}$  result in lower output voltages. When  $V_{BIAS} > 2.9V$ , the BIAS supply overrides the input voltage and supplies power to the internal regulator. When  $V_{BIAS} > 4.5V$ , BIAS powers the LS-FET driver.

Using BIAS to power the internal regulator improves efficiency. It is recommended to connect BIAS to the regulated output voltage when it is in the 2.9V to 5.5V range. When the output voltage is out of this range, an external supply of  $>2.9V$  to  $>4.5V$  can be used to power BIAS.

### Enable (EN) Control

The MP2420 has a dedicated enable control (EN). When  $V_{IN}$  goes high, EN enables and disables the chip (high logic). Its falling threshold is a consistent 1.2V, and the rising threshold is about 350mV higher. When floating, EN is pulled down internally to GND to disable the chip.

When  $EN = 0V$ , the chip enters the lowest shutdown current mode. When EN is higher than zero but lower than its rising threshold, the chip remains in shutdown mode with a slightly larger shutdown current.

A Zener diode is connected internally from EN to GND. The typical clamping voltage of the Zener diode is 6.5V.  $V_{IN}$  can be connected to EN through a high ohm ( $\Omega$ ) resistor if the system does not have another logic input acting as the EN signal. The resistor must be designed to limit the EN sink current to less than 150 $\mu$ A. Note that there is an internal 3M $\Omega$  resistor from EN to GND, so the external pull up resistor should be smaller than  $\frac{[V_{IN(MIN)} - 1.55V] \times 3M}{1.55V}$  to ensure that EN can turn on at the lowest operation ( $V_{IN}$ ).

### Under-Voltage Lockout (UVLO)

$V_{IN}$  under-voltage lockout (UVLO) protects the chip from operating below its operational supply voltage range. The UVLO rising threshold is about 4.2V while its trailing threshold is about 3.75V.

### Soft Start (SS)

The reference-type soft start prevents the converter output voltage from overshooting during start-up. When the chip starts, the internal circuitry generates a constant current to charge the external soft-start capacitor. The SS voltage ramps up slowly from 0V at a pace set by the SS time. When  $V_{SS}$  is less than  $V_{REF}$ ,  $V_{SS}$  overrides  $V_{REF}$ , and the FB comparator uses  $V_{SS}$  as the reference instead of  $V_{REF}$ . When  $V_{SS}$  is higher than  $V_{REF}$ ,  $V_{REF}$  resumes control.

$V_{SS}$  can be much smaller than  $V_{FB}$ , but it can only barely exceed  $V_{FB}$ . If  $V_{FB}$  drops,  $V_{SS}$  tracks  $V_{FB}$ . This function prevents an output voltage overshoot during short-circuit recovery. When the short circuit is removed, a new SS process ramps up.

### Thermal Shutdown

Thermal shutdown prevents a thermal runaway on the chip. When the silicon die reaches temperatures exceeding its upper threshold, the entire chip shuts down. When the temperature falls below its lower threshold, the chip is enabled again.

### Floating Driver and Bootstrap Charging

The external bootstrap capacitor powers the floating HS-FET driver. This floating driver has its own UVLO protection. This UVLO's rising threshold is about 2.4V with a hysteresis of about 300mV. During the UVLO, the SS voltage resets to zero. When the UVLO is disabled, the regulator follows the soft-start process.

The dedicated internal bootstrap regulator charges and regulates the bootstrap capacitor to about 5V. When the voltage difference between BST and SW falls below its working parameters, a PMOS pass transistor connected from  $V_{IN}$  to BST turns on to charge the bootstrap capacitor. The current path runs from  $V_{IN}$  to BST to SW. The external circuit must have sufficient voltage headroom to accommodate charging.

As long as  $V_{IN}$  is sufficiently higher than SW, the bootstrap capacitor can charge. When the HS-FET is on,  $V_{IN}$  is about equal to SW, and the bootstrap capacitor cannot charge. The optimal charging period occurs when the LS-FET is on, and  $V_{IN} - V_{SW}$  is at its largest.  $V_{SW}$  is equal to  $V_{OUT}$  when there is no current in the inductor. The difference between  $V_{IN}$  and  $V_{OUT}$  charges the bootstrap capacitor.

If the internal circuit does not have sufficient voltage and time to charge the bootstrap capacitor, extra external circuitry can be used to ensure that the bootstrap voltage operates in its normal region.

### Start-Up and Shutdown

If both  $V_{IN}$  and  $V_{EN}$  are higher than their appropriate thresholds, the chip starts up. The reference block starts first, generating stable reference voltages and currents, and then it enables the internal regulator. The regulator provides a stable supply for the rest of the device.

If the internal supply rail is high, an internal timer holds the power MOSFET off for about 50 $\mu$ s to clear up any start-up glitches. When the soft-start block is enabled, the SS output voltage is first held low and then slowly ramps up.

Three events can shut down the chip:  $V_{EN}$  low,  $V_{IN}$  low, and thermal shutdown. During the shutdown procedure, the signaling path is blocked first to avoid any fault triggering. The internal supply rails are then pulled down. The floating driver is not subject to this shutdown command, but its charging path is disabled.

### Power OK (POK)

POK is an open-drain power good output. A high output indicates that  $V_{OUT}$  is higher than 90% of its nominal value. POK is pulled down in shutdown mode.

### Reference Voltage Output ( $V_{REF}$ )

$V_{REF}$  has an output reference voltage of 1V. It has up to 500 $\mu$ A of source current capability.

## WATCHDOG SECTION:

### Supply Voltage

A supply voltage of  $V_{CC} = 5V \pm 10\%$  is recommended for normal operation. WDO is pulled low when  $V_{CC}$  rises to 1V or above. After  $V_{CC}$  rises to 4.65V, WDO remains at a low level for  $t_0$  to reset the MCU.

### Timer

Calculate the period  $T$  ( $\mu s$ ) with Equation (1):

$$T(\mu s) = 15.75 \times R_{TIMER} (k\Omega) + 73.5 \quad (1)$$

Calculate the  $R_{TIMER}$  ( $k\Omega$ ) with Equation (2):

$$R_{TIMER} (k\Omega) = 0.063 \times T(\mu s) - 4.67 \quad (2)$$

For example, if  $R_{TIMER} = 51k\Omega$ , then  $T \approx 0.88ms$ .

### Monitoring the MCU Synchronization Signal

When the watchdog is in a sync signal monitoring state, the watchdog IC receives a WDI\_OK signal from the MCU within  $t_1$ . The timer resets, and the watchdog enters normal operation (WDI remains low for 10 $\mu s$  to 5ms). If the watchdog does not receive the WDI\_OK signal from the MCU during  $t_1$ , it generates a reset signal and enters a sync signal monitor state again.

### Short Window Mode

If the MCU and watchdog are synchronized correctly and MODE is low, the watchdog works in a short window mode if WDI\_OK is received in a window close state ( $t_2$ ). The watchdog outputs a reset signal and enters the sync signal monitoring state.

If WDI\_OK is received in a window open state ( $t_3$ ), the watchdog enters a window close state. The MCU is in normal operation in this situation.

If WDI\_OK is not received in  $t_2+t_3$ , the watchdog outputs a reset signal and enters the sync signal monitoring state.

MODE is pulled to high during the short window mode, and the watchdog then enters long window mode.

### Long Window Mode

If the MCU and watchdog are synchronized correctly and MODE is high, the watchdog works in long window mode if WDI\_OK is received in a window close state ( $t_4$ ). The watchdog outputs a reset signal and enters a sync signal monitoring state.

If WDI\_OK is received in a window open state ( $t_5$ ), the watchdog enters a window close state. The MCU is in normal operation in this situation.

If WDI\_OK is not received in  $t_4+t_5$ , the watchdog then outputs a reset signal and enters the sync signal monitoring state.

MODE is pulled low during the long window mode, and the watchdog enters a short window mode.

### Watchdog Disable

Pull /WD\_DIS low to disable the watchdog, and pull /WD\_DIS high to enable the watchdog. It has a weak internal pull-up, so leaving /WD\_DIS open enables the watchdog.

### WDI Error

The WDI signal remaining at a low level for longer than the max WDI\_OK pulse width is regarded as an error. When this error occurs, WDO is pulled down until WDI rises to its high level again.

## TIMING DIAGRAM

### Power-On Reset and No Sync Signal

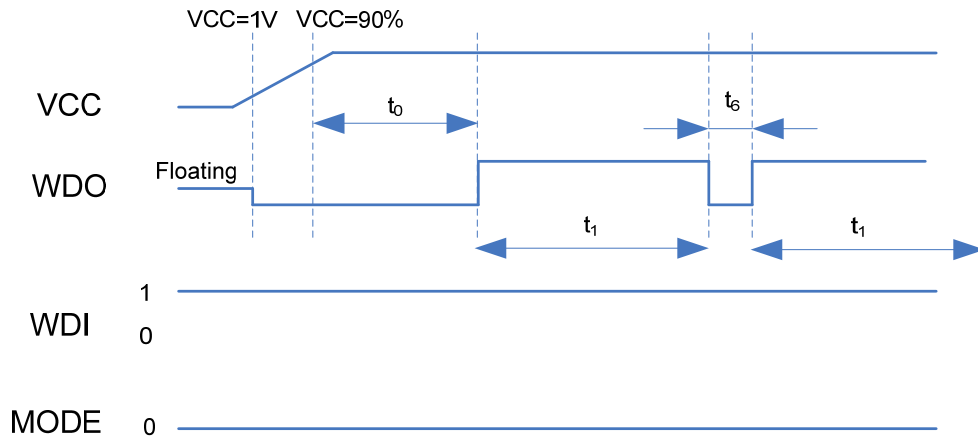

### Synchronized by WDI and Triggered in Open Window (MODE = 0, Short Window Mode)

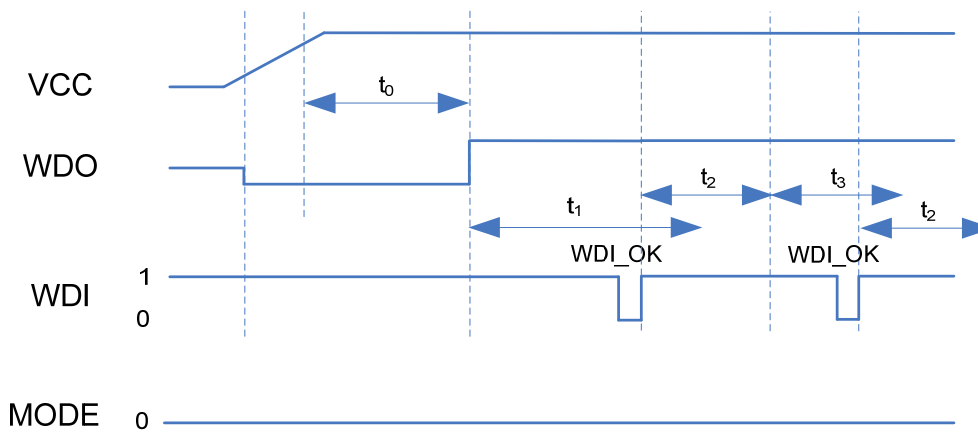

### Synchronized by WDI and No Trigger Signal (MODE = 0, Short Window Mode)

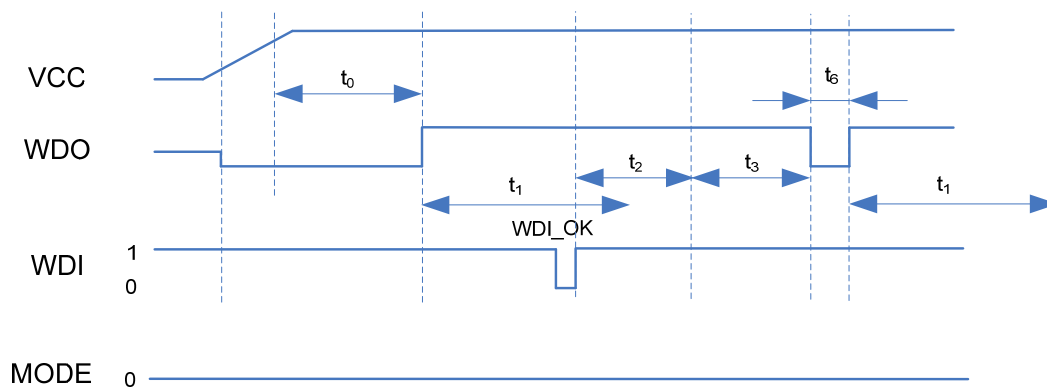



**Synchronized by WDI and Triggered in Closed Window (MODE = 0, Short Window Mode)**

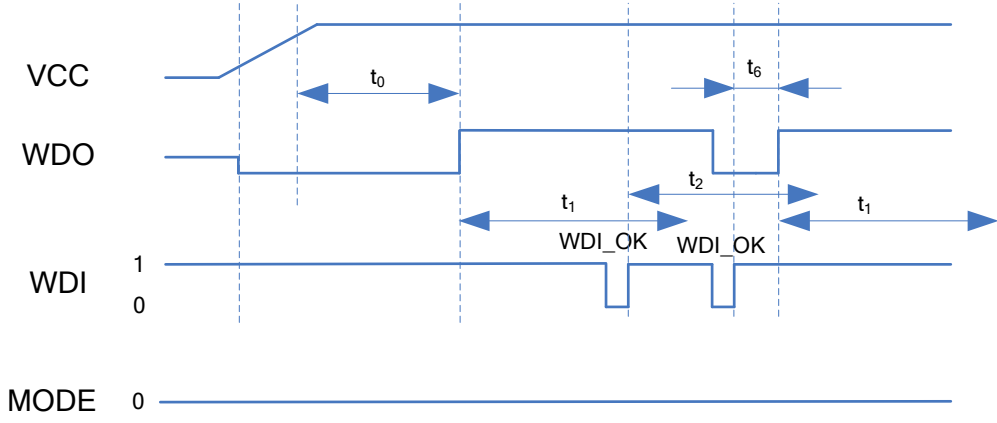

**NOTE:** When the WDI\_OK rising edge approaches WDO when it is low, the  $t_6$  timer is reset. In the situation above, the WDO reset signal keeps  $t_6 + \text{WDI\_OK}$  time.

**Synchronized by WDI and Triggered in Open Window (MODE = 1, Long Window Mode)**

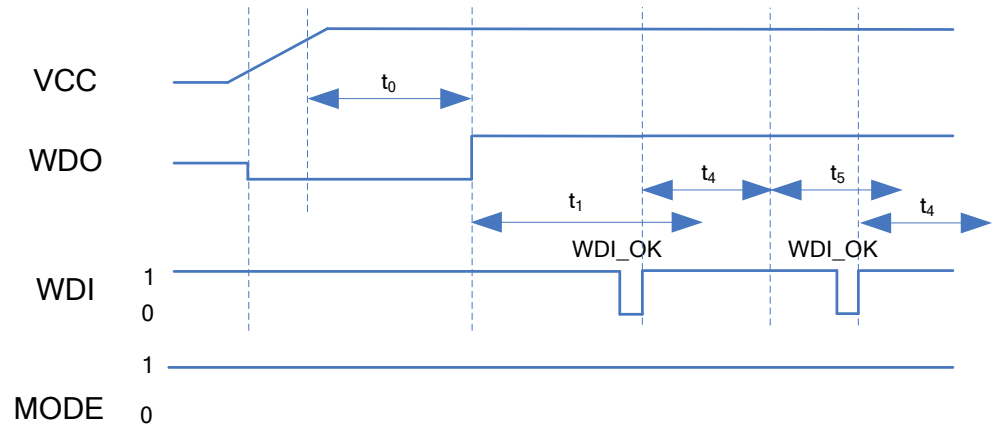

**Synchronized by WDI and No Trigger Signal (MODE = 1, Long Window Mode)**

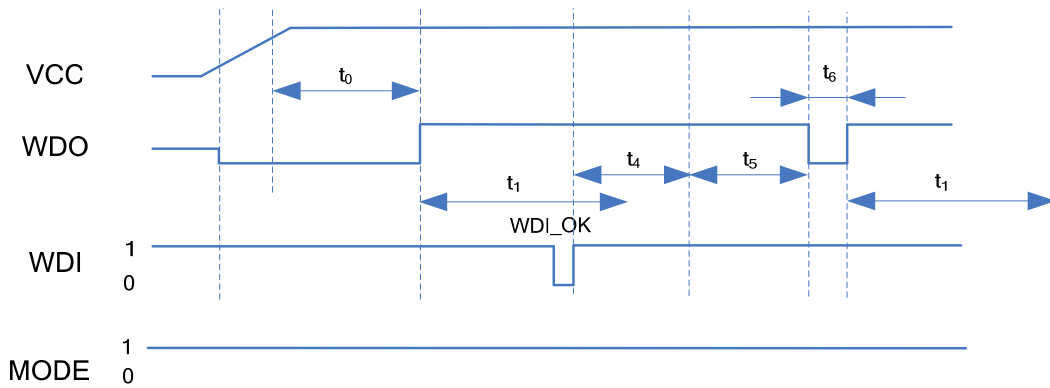

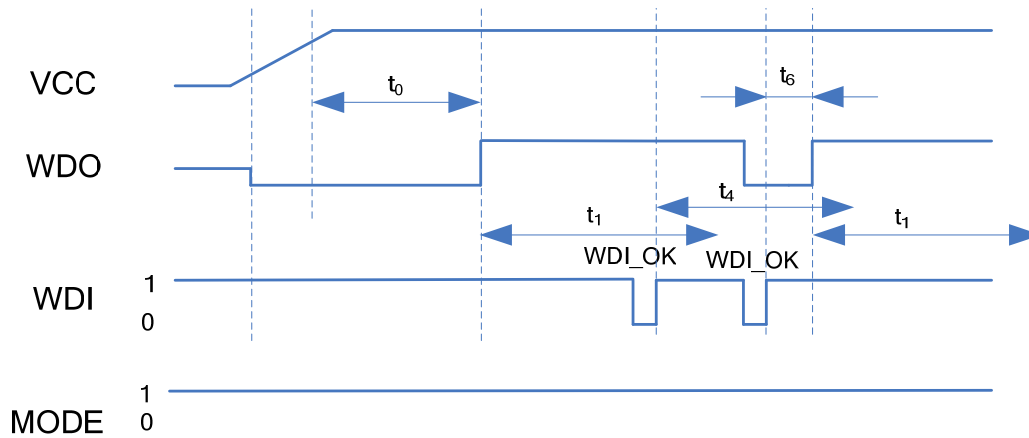

**Synchronized by WDI and Triggered in Closed Window (MODE = 1, Long Window Mode)**

**NOTE:** When the WDI\_OK rising edge approaches WDO when it is low, the  $t_6$  timer is reset. In the situation above, the WDO reset signal keeps  $t_6 + \text{WDI\_OK}$  time.

STATE DIAGRAM

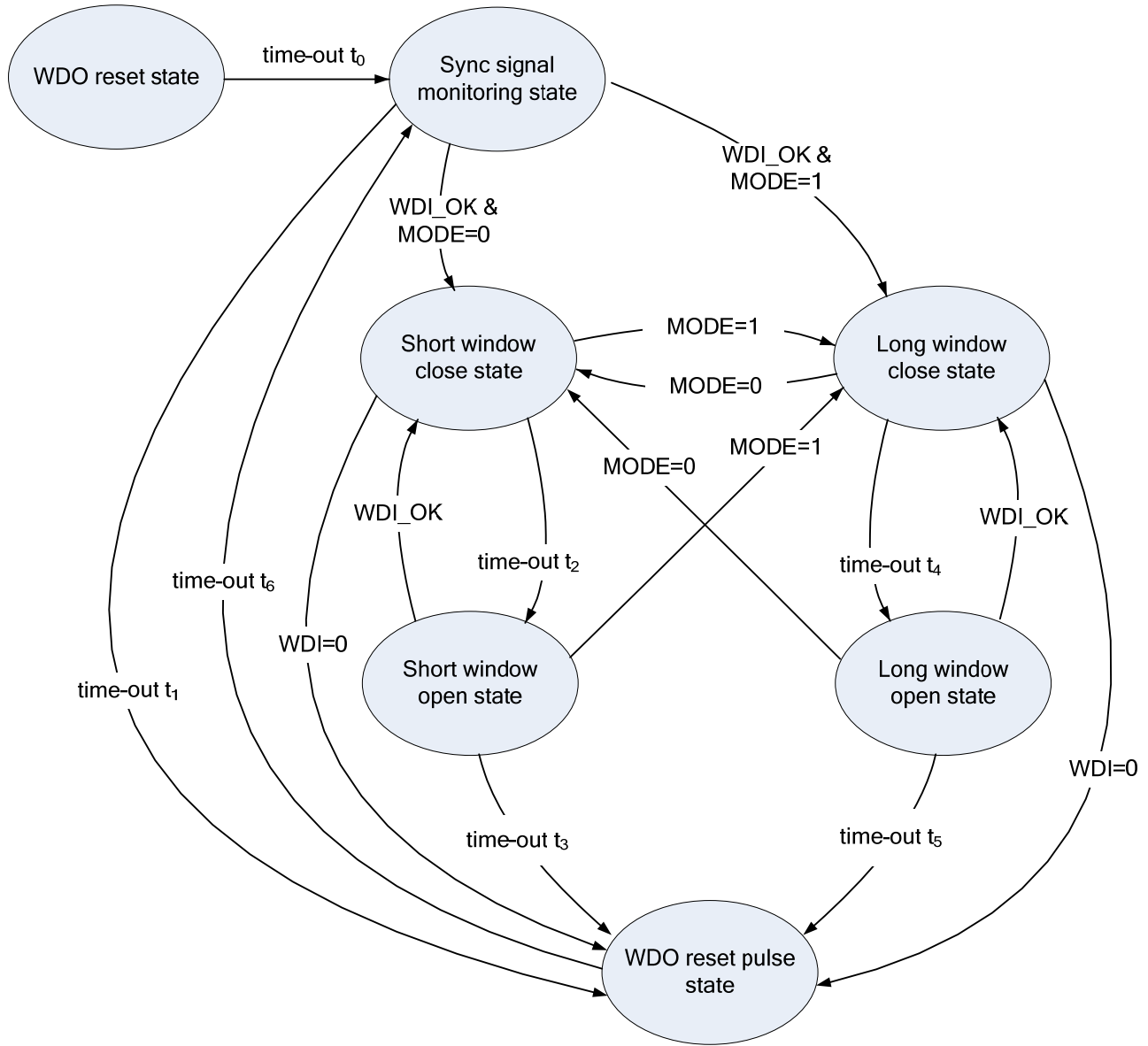

**NOTE:** The state diagram above does not show a WDI error situation.

## APPLICATION INFORMATION

### Selecting the Inductor

$I_{peak}$  is fixed, and the inductor value can be determined with Equation (3):

$$L = \frac{V_{OUT} \times (V_{IN} - V_{OUT})}{V_{IN} \times I_{peak} \times f_s} \quad (3)$$

Where  $f_s$  is the switching frequency at the maximum output current.

A larger inductor value results in a lower switching frequency and higher efficiency. However, the larger value inductor has a larger physical size, a higher series resistance, a lower saturation current, and slow load transient dynamic performance. The inductor value has a lower limit, which is determined by the minimum on time. To keep the inductor functioning properly, the inductor value should be higher than  $L_{MIN}$  and can be derived from Equation (4):

$$L_{MIN} = \frac{V_{IN(MAX)} \times t_{ON(MIN)}}{I_{peak}} \quad (4)$$

Where  $V_{IN(MAX)}$  is the maximum value of the input voltage, and  $t_{ON(MIN)}$  is the 115ns minimum switch-on time.

### Switching Frequency

The switching frequency can be estimated with Equation (5):

$$f_s = \frac{2 \times I_o \times V_{OUT} \times (V_{IN} - V_{OUT})}{I_{peak}^2 \times V_{IN} \times L} \quad (5)$$

A larger inductor can achieve a lower  $f_s$ .  $f_s$  increases as  $I_o$  increases. When  $I_o$  increases to its maximum value ( $I_{peak}/2$ ),  $f_s$  reaches its highest value. The maximum  $f_s$  value can be estimated with Equation (6):

$$f_{s(max)} = \frac{V_{OUT} \times (V_{IN} - V_{OUT})}{I_{peak} \times V_{IN} \times L} \quad (6)$$

### Setting the Output Voltage

The output voltage is set using a resistive voltage divider from the output voltage to FB. To achieve the desired output voltage, select the resistor divider with Equation (7):

$$\frac{R1}{R2} = \frac{V_{OUT}}{V_{REF}} - 1 \quad (7)$$

Where  $V_{REF}$  is the FB reference voltage (1V).

The current flowing into the resistor divider increases the supply current, especially at no-load and light-load conditions. The  $V_{IN}$  supply current caused by the feedback resistors can be calculated with Equation (8):

$$I_{IN\_FB} = \frac{V_{OUT}}{R1 + R2} \times \frac{V_{OUT}}{V_{IN}} \times \frac{1}{\eta} \quad (8)$$

Where  $\eta$  is the efficiency of the regulator.

To reduce this current, it is recommended to use resistors in the M $\Omega$  range. The recommended values of the feedback resistors are shown in Table 1.

**Table 1: Resistor Selection for Common Output Voltages**

V <sub>OUT</sub> (V)	R1 (k $\Omega$ )	R2 (k $\Omega$ )
3.3	1200	523
5	1200	300

### Under-Voltage Lockout (UVLO) Point Setting

The MP2420 has an internal, fixed, under-voltage lockout (UVLO) threshold. The rising threshold is about 4.2V while its trailing threshold is about 3.75V. External resistor dividers placed between EN and VIN can be used to achieve a higher equivalent UVLO threshold (see Figure 3).

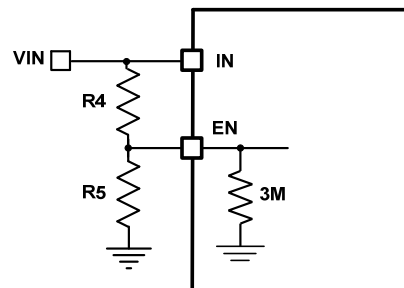

**Figure 3: Adjustable UVLO Using EN**

The UVLO threshold can be calculated with Equation (9) and Equation (10):

$$\text{UVLO}_{\text{TH\_Rising}} = \left(1 + \frac{R4}{3M//R5}\right) \times \text{EN}_{\text{TH\_Rising}} \quad (9)$$

$$\text{UVLO}_{\text{TH\_Falling}} = \left(1 + \frac{R4}{3M//R5}\right) \times \text{EN}_{\text{TH\_Falling}} \quad (10)$$

### Soft-Start Capacitor

The soft-start time is the duration of an internal 5 $\mu$ A current source charging the SS capacitor from 0 to the FB reference voltage (1V). The SS capacitor can be determined with Equation (11):

$$C_{\text{SS}} = 5 \times t_{\text{SS}} (\mu\text{F}) \quad (11)$$

### Feed-Forward Capacitor

The HS-FET turns on when FB drops below the reference voltage, producing ideal load transient performance. However, this also causes the HS-FET to be very sensitive to the FB voltage during turn-on. The HS-FET is affected easily at turn-on, which can trigger a Fsw jitter. Fsw jitter occurs most often when the Vo ripple is very small. To improve jitter performance, it is recommended to use a small feed-forward capacitor of about 39pF between Vo and FB.

## TYPICAL APPLICATION CIRCUITS

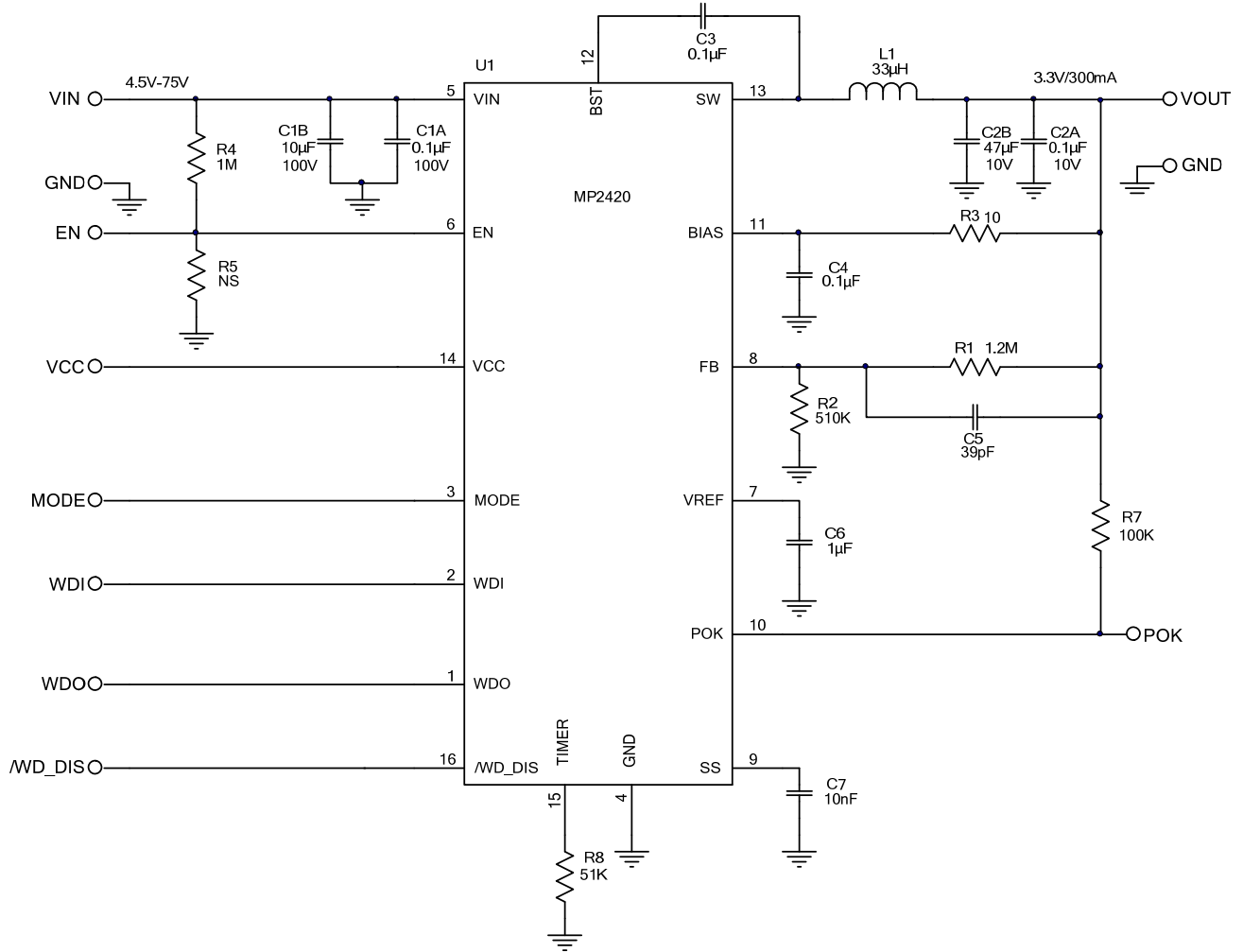

**Figure 4: 3.3V Output Typical Application Circuit**

# PACKAGE INFORMATION

## TSSOP-16 EP

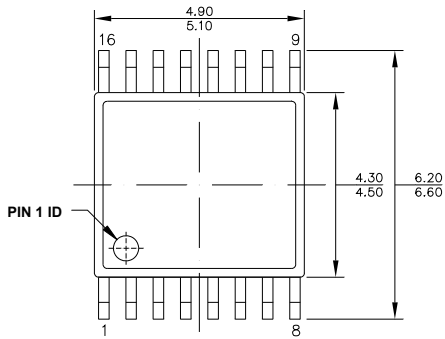

**TOP VIEW**

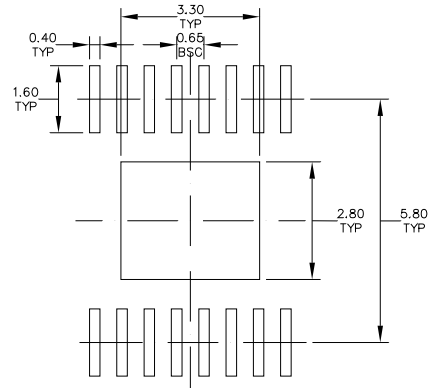

**RECOMMENDED LAND PATTERN**

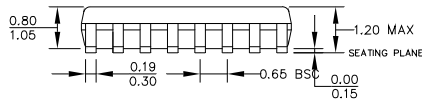

**FRONT VIEW**

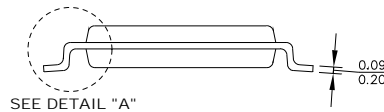

**SIDE VIEW**

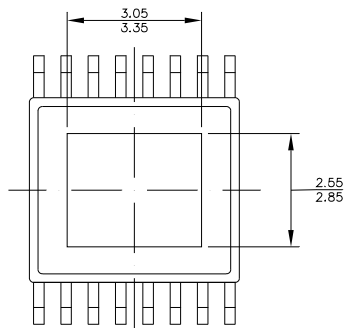

**BOTTOM VIEW**

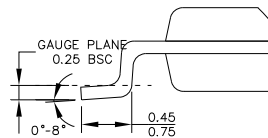

**DETAIL "A"**

**NOTE:**

- 1) ALL DIMENSIONS ARE IN MILLIMETERS.
- 2) PACKAGE LENGTH DOES NOT INCLUDE MOLD FLASH, PROTRUSION OR GATE BURR.
- 3) PACKAGE WIDTH DOES NOT INCLUDE INTERLEAD FLASH OR PROTRUSION.
- 4) LEAD COPLANARITY (BOTTOM OF LEADS AFTER FORMING) SHALL BE 0.10 MILLIMETERS MAX.
- 5) DRAWING CONFORMS TO JEDEC MO-153, VARIATION ABT.
- 6) DRAWING IS NOT TO SCALE.

**NOTICE:** The information in this document is subject to change without notice. Please contact MPS for current specifications. Users should warrant and guarantee that third party Intellectual Property rights are not infringed upon when integrating MPS products into any application. MPS will not assume any legal responsibility for any said applications.